

Contents

EC DECLARATION OF CONFORMITY FOR MACHINES	p. 11
WARNINGS FOR THE INSTALLER	p. 11
1. DESCRIPTION AND TECHNICAL SPECIFICATIONS	p. 12
1.1. DIMENSIONS	p. 12
2. ELECTRIC DEVICES (standard system)	p. 12
3. INSTALLING THE AUTOMATED SYSTEM	p. 13
3.1. PRELIMINARY CHECKS	p. 13
3.2. INSTALLATION DIMENSIONS	p. 13
3.2.1. GENERAL RULES FOR DETERMINING THE INSTALLATION DIMENSIONS	p. 13
3.3. INSTALLATION OF THE OPERATORS	p. 13
4. START-UP	p. 15
4.1. ADJUSTING THE ANTI-CRUSHING SYSTEM	p. 15
5. FINAL OPERATIONS	p. 16
6. AUTOMATED SYSTEM TEST	p. 16
7. MANUAL OPERATION	p. 16
8. RESTORING NORMAL OPERATION MODE	p. 17
9. SPECIAL APPLICATIONS FOR SWING LEAF GATES	p. 17
9.1. OPENING TOWARD THE OUTSIDE, WITH OPERATOR INSTALLED INSIDE	p. 17
10. MAINTENANCE	p. 17
11. REPAIRS	p. 17
12. TROUBLE SHOOTING	p. 18

Read this instruction manual to the letter before you begin to install the product.

Symbol  highlights notes that are important for people's safety and for the good condition of the automated system.

Symbol  draws your attention to the notes about the product's characteristics or operation.



FAAC S.p.A.
Via Benini, 1
40069 Zola Predosa (BO) - ITALIA
Tel.: 051/61724 - Fax: 051/758518
www.faac.it

732870 Rev. B

EC DECLARATION OF CONFORMITY FOR MACHINES (DIRECTIVE 98/37/EC)

Manufacturer: FAAC S.p.A.

Address: Via Benini, 1 - 40069 Zola Predosa BOLOGNA - ITALY

Declares that: 422 mod. operator,

- is built to be integrated into a machine or to be assembled with other machinery to create a machine under the provisions of Directive 98/37/EC;
- conforms to the essential safety requirements of the following EEC directives:

73/23/EEC and subsequent amendment 93/68/EEC.
89/336/EEC and subsequent amendment 92/31/EEC and 93/68/EEC

and also declares that it is prohibited to put into service the machinery until the machine in which it will be integrated or of which it will become a component has been identified and declared as conforming to the conditions of Directive 98/37/EC.

Bologna, 01 January 2005

The Managing Director

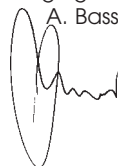
A. Bassi

WARNINGS FOR THE INSTALLER GENERAL SAFETY OBLIGATIONS

- 1) **ATTENTION! To ensure the safety of people, it is important that you read all the following instructions. Incorrect installation or incorrect use of the product could cause serious harm to people.**
- 2) Carefully read the instructions before beginning to install the product.
- 3) Do not leave packing materials (plastic, polystyrene, etc.) within reach of children as such materials are potential sources of danger.
- 4) Store these instructions for future reference.
- 5) This product was designed and built strictly for the use indicated in this documentation. Any other use, not expressly indicated here, could compromise the good condition/operation of the product and/or be a source of danger.
- 6) FAAC declines all liability caused by improper use or use other than that for which the automated system was intended.
- 7) Do not install the equipment in an explosive atmosphere: the presence of inflammable gas or fumes is a serious danger to safety.
- 8) The mechanical parts must conform to the provisions of Standards EN 12604 and EN 12605.
For non-EU countries, to obtain an adequate level of safety, the Standards mentioned above must be observed, in addition to national legal regulations.
- 9) FAAC is not responsible for failure to observe Good Technique in the construction of the closing elements to be motorised, or for any deformation that may occur during use.
- 10) The installation must conform to Standards EN 12453 and EN 12445.
For non-EU countries, to obtain an adequate level of safety, the Standards mentioned above must be observed, in addition to national legal regulations.
- 11) Before attempting any job on the system, cut out electrical power.
- 12) The mains power supply of the automated system must be fitted with an all-pole switch with contact opening distance of 3mm or greater. Use of a 6A thermal breaker with all-pole circuit break is recommended.
- 13) Make sure that a differential switch with threshold of 0.03 A is fitted upstream of the system.
- 14) Make sure that the earthing system is perfectly constructed, and connect metal parts of the means of the closure to it.
- 15) The safety devices (EN 12978 standard) protect any danger areas against **mechanical movement Risks**, such as crushing, dragging, and shearing.
- 16) Use of at least one indicator-light (e.g. FAACLIGHT) is recommended for every system, as well as a warning sign adequately secured to the frame structure, in addition to the devices mentioned at point "15".
- 17) FAAC declines all liability as concerns safety and efficient operation of the automated system, if system components not produced by FAAC are used.
- 18) For maintenance, strictly use original parts by FAAC.
- 19) Do not in any way modify the components of the automated system.
- 20) The installer shall supply all information concerning manual operation of the system in case of an emergency, and shall hand over to the user the warnings handbook supplied with the product.
- 21) Do not allow children or adults to stay near the product while it is operating.
- 22) Keep remote controls or other pulse generators away from children, to prevent the automated system from being activated involuntarily.
- 23) Transit through the leaves is allowed only when the gate is fully open.
- 24) The user must not attempt any kind of repair or direct action whatever and contact qualified personnel only.
- 25) Maintenance: check at least every 6 months the efficiency of the system, particularly the efficiency of the safety devices (including, where foreseen, the operator thrust force) and of the release devices.
- 26) **Anything not expressly specified in these instructions is not permitted.**

422 AUTOMATION SYSTEM

These instructions apply to the following models:

422 CBCS - 422 CBACS - 422 SBS - 422 CBC - 422 CBAC - 422 SB - 422 CBC PED. - 422 SB PED.

The FAAC 422 automated system for swing leaf gates consists of an enbloc composed of an electric pump and a hydraulic piston which transmits drive to the leaf.
The models with a hydraulic locking do not require installation of electric locks, as they guarantee mechanical locking of the leaf when the motor is not operating.
The models without a hydraulic locking, require the installation of electric locks to ensure the leaf is mechanically locked.

The 422 automated systems were designed and built to automate swing leaf gates. Do not use for any other purpose.

1. DESCRIPTION AND TECHNICAL SPECIFICATIONS

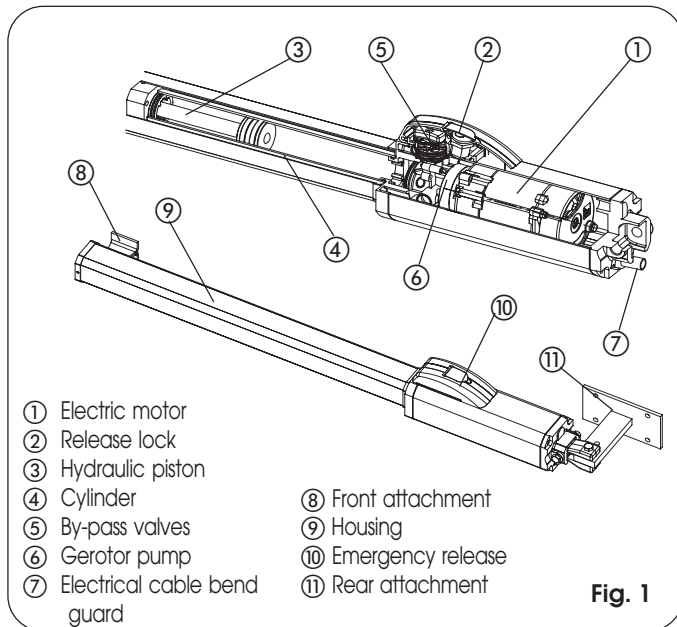

Fig. 1

Tab. 1: Technical specifications of "422 Operator"

MODEL	CBCS	CBACS	SBS	CBC	CBAC	SB	PED. CBC	PED. SB
Traction/thrust force max (daN)	690	690	690	500	500	500	380	380
Rod effective stroke (mm)	240	240	240	240	240	240	160	160
Rod linear speed (cm/s)	1	1	1	1,3	1,3	1,3	2	2
Use frequency (cycles/hour)	55	55	55	55	55	55	70	70
Pump flow-rate (l/min)	0,75	0,75	0,75	1	1	1	1,5	1,5
Hydraulic locking	(1)	(2)	/	(1)	(2)	/	(1)	/
Leaf maximum length (m)	1,80	1,80	3	1,80	1,80	3	(3)	(3)
Operator weight (Kg)	7							
Power supply	230 Vac (+6% -10%) / 50 Hz.							
Absorbed power (W)	220							
Absorbed current (A)	1							
Electric motor (rpm)	1400 - 4 poles							
Thermal protection on winding	120 °C							
Thrust capacitor	8uF / 400 V.							
Operating ambient temperature	- 40°C + 55 °C							
Protection class	IP55							

(1) Closing - (2) Opening and closing
(3) Max. 1,20 m. - Min. 0,80 m.

1.1. DIMENSIONS

Fig. 2

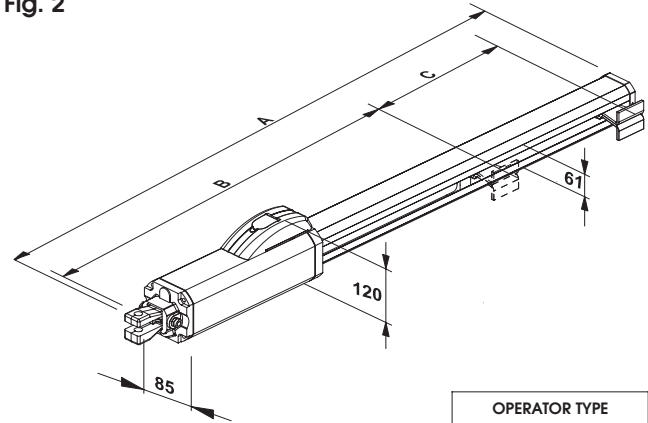

2. ELECTRIC DEVICES (standard system)

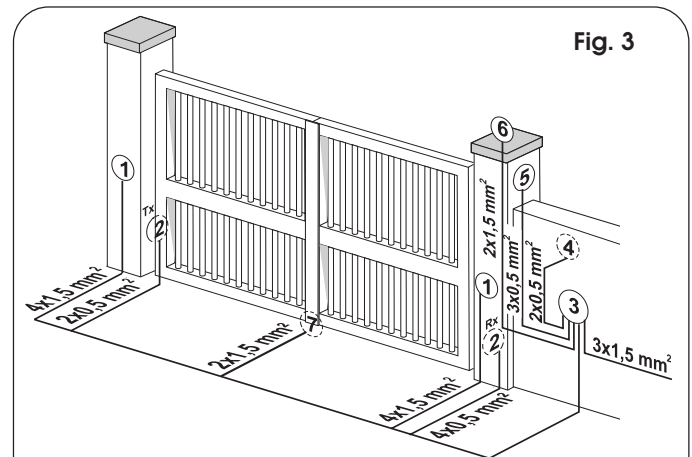

Fig. 3

- ① Operators mod. 400 (provide a connector block for each operator)
- ② Photocells
- ③ Electronic control unit
- ④ Key operated push-button T 10
- ⑤ Radio receiver
- ⑥ Flashing light
- ⑦ Electric lock (if necessary)

- 1) To lay the electrical cables, use adequate rigid and/or flexible pipes.
- 2) Always separate the connection cables of the low voltage accessories from the 230 V power cables. Use separate sheaths to avoid any type of interference.

3. INSTALLING THE AUTOMATED SYSTEM

3.1. PRELIMINARY CHECKS

To ensure a correctly operating automated system, the structure of the existing gate or gate to be built must satisfy the following requirements:

- Max length of leaves according to the dimensions of Table 1.
- A strong and rigid leaf structure.
- Smooth, uniform leaves movement, without any irregular friction during the entire travel;
- Existing hinges in good condition.
- Travel limit mechanical stops must be provided.

We advise you to carry out the metalwork jobs before installing the automated system.

The condition of the structure directly influences the reliability and safety of the automated system.

3.2. INSTALLATION DIMENSIONS

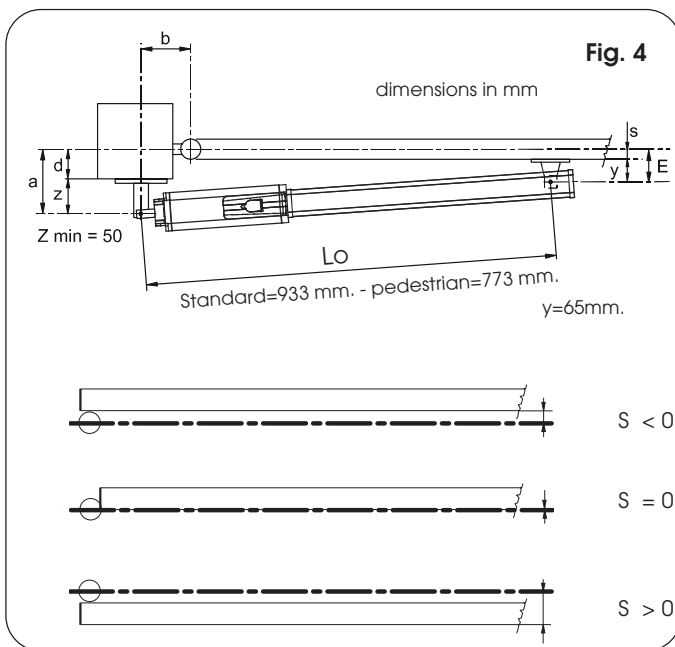

Table A: Recommended dimensions for standard operators

Opening angle	a (mm)	b (mm)	c(*) (mm)	d(**) (mm)
90°	120	120	240	70
110°	100	100	240	50

(*) Rod effective stroke (**) maximum dimension

Table B: Recommended dimensions for long operators

Opening angle	a (mm)	b (mm)	c(*) (mm)	d(**) (mm)
90°	80	80	160	30

(*) Rod effective stroke (**) maximum dimension

c = The effective rod stroke is shorter than the maximum stroke, in order to prevent the rod from reaching its stop point internally, during the opening and closing stages.

3.2.1. GENERAL RULES FOR DETERMINING THE INSTALLATION DIMENSIONS

If the dimensions indicated in table A or B cannot be executed, the following must be considered in order to determine different measurements:

- to obtain **90° opening of the leaf: a + b = c.**
- to obtain **over 90° opening of the leaf: a + b < c.**
- **lower a and b dimensions will result in higher speeds.** We advise you to observe the current legal regulations;
- **limit the difference of the a and b dimensions to within 40 mm:** higher differences will considerably vary speed during the opening and closing motion;
- for reasons of operator dimensions, the **minimum Z dimension is 50 mm** (Fig. 4);
- if the pilaster dimensions or the position of the hinge (dimension **d**) do not make it possible to contain dimension **a** to the required size, a niche must be made in the pilaster as shown in Fig. 5;
- dimension **a** must always be larger than dimension **E**.

For installations opening toward the outside, refer to paragraph 9.1.

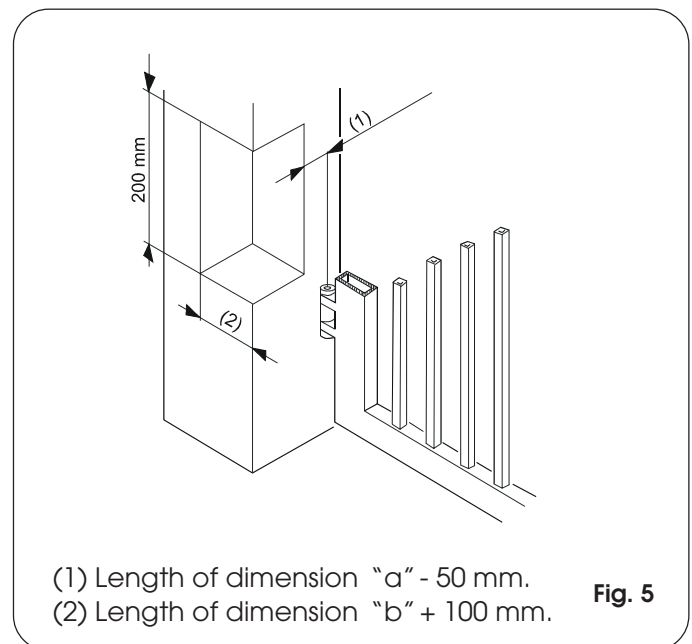

3.3. INSTALLATION OF THE OPERATORS

- 1) Fasten the rear attachment on the pilaster, following the indications in **Tables A/B**. Modify, if necessary, the length of the supplied attachment.

Attention: To avoid compromising good operator functionality, we recommend you to respect the indicated dimensions.

- For iron pilasters, accurately weld the rear attachment (ref. 2, Fig. 6) directly on the pilaster.
- For masonry pilasters, select one of the following solutions:
 - A) appropriately lay a walling-in plate and then accurately weld the rear attachment.
 - B) secure, with screws and expansion plugs, the rear attachment plate (ref. a, Fig. 6) to the pilaster and then accurately weld the rear attachment to the plate as shown in Fig. 6.

- 2) Secure the operator to the rear attachment with the supplied screws (Fig. 6).
- 3) Screw, halfway down, the front attachment onto the rod (ref. ① Fig.8) and tighten with the supplied nut.
- 4) Release the operator (see chapter 7).
- 5) Fully remove the rod to its stop point and make it recede by about 5 mm (Fig.7).

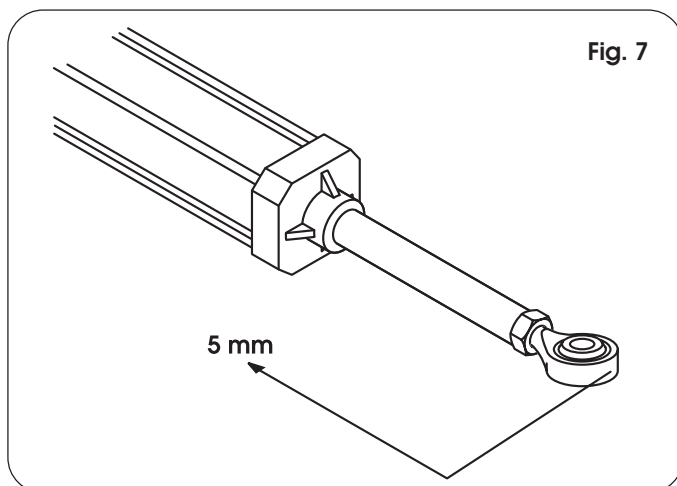
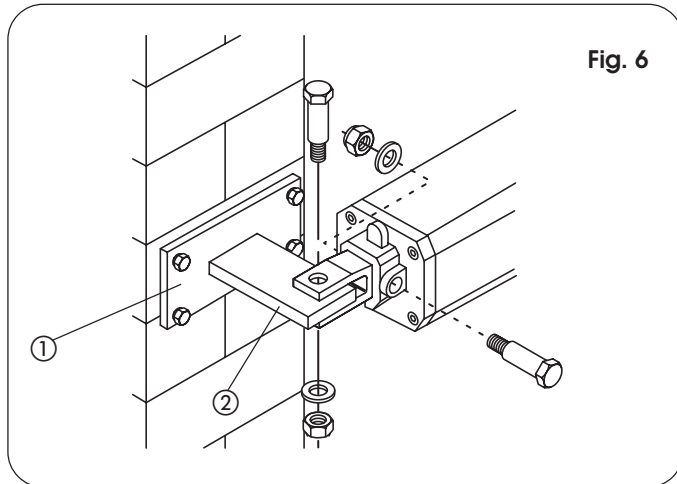



- 6) Relock the operator (see chapter 8).
- 7) Fit the front attachment onto the rod (ref. ② Fig. 8)
- 8) Close the gate leaf and, keeping the operator perfectly horizontal, find the position of the front attachment (Fig. 9) on the leaf.
- 9) Provisionally fix the front attachment on the leaf with two weld spots, protecting the rod against any welding waste.

 If the gate structure does not permit the attachment to be firmly fastened, take action on the structure, creating a solid support base.

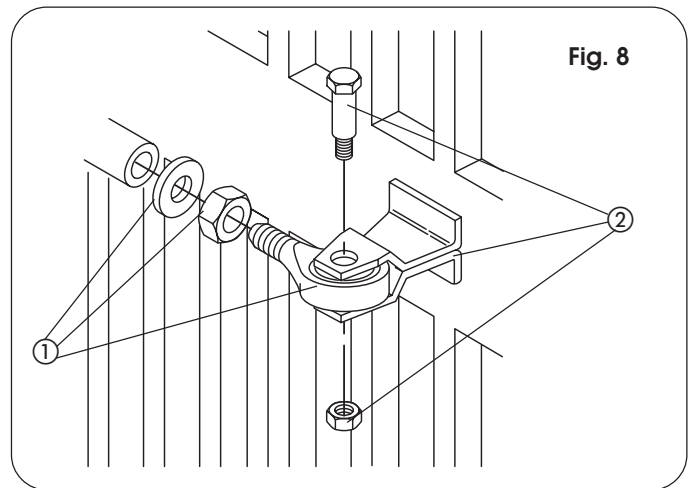
- 10) Release the operator and manually check if the gate is free to open completely stopping on the travel limit mechanical stops and if leaf movement is good and friction-free.
- 11) Definitively weld the front attachment on the leaf. To do this, temporarily release the operator from the



attachment to prevent welding waste from damaging it (Fig.10).

- A)  We advise you to grease all the securing pins of the attachments.
- B)  If welding is impossible, the plates of the front and rear attachments are designed to be secured with screws if necessary.

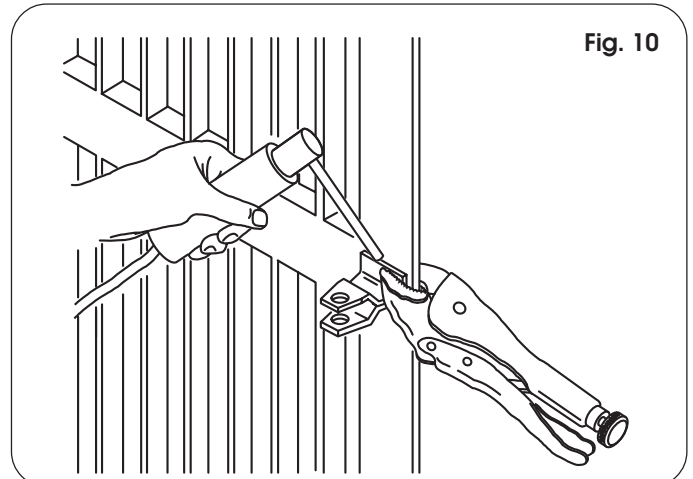
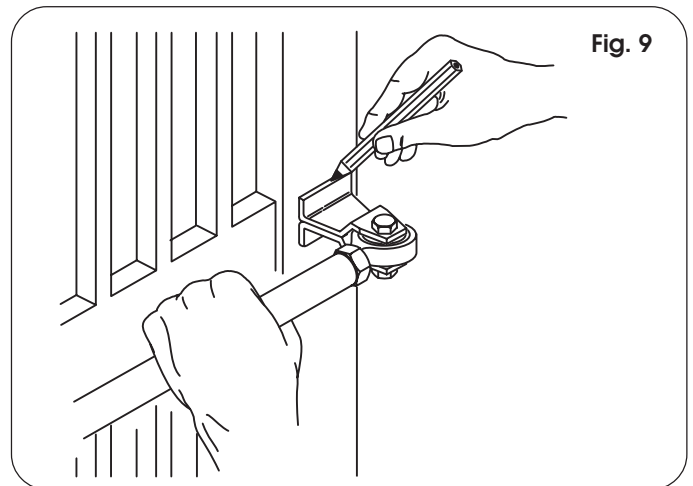
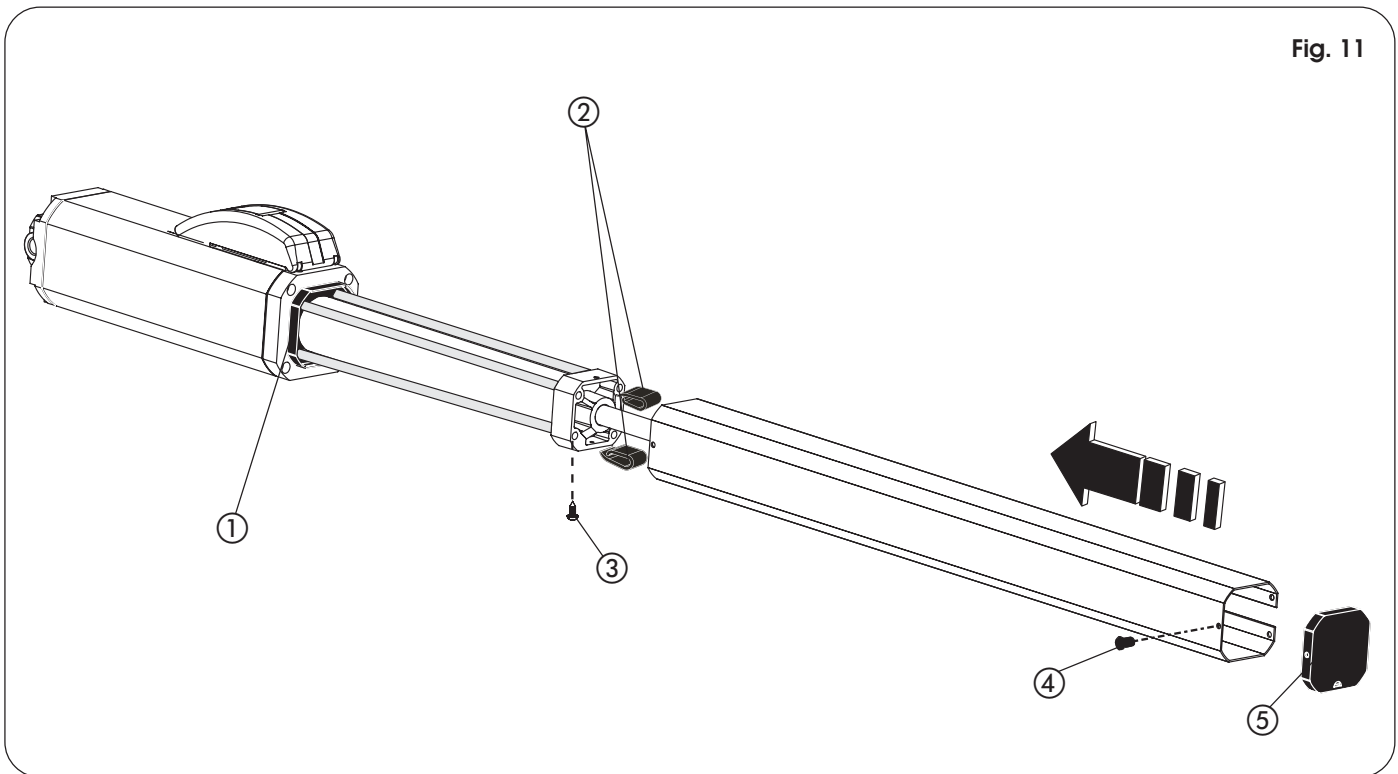

Fig. 11



12) Prepare the protective housing and fit it on the operator as shown in Fig. 11.

- A) Insert the two anti-vibration spacers ② onto the front flange.
- B) Introduce the housing, pressing it firmly on the rear cover ①.
- C) Secure the housing with the self-tapping screw ③.
- D) Fit the front cover ⑤ on the housing and fasten it with FIX plug ④.

13) Fit the electric cable bend guard (ref.③, Fig. 14).

14) Re-lock the operator and make the electrical connections of the selected electronic control unit following the relevant instructions.

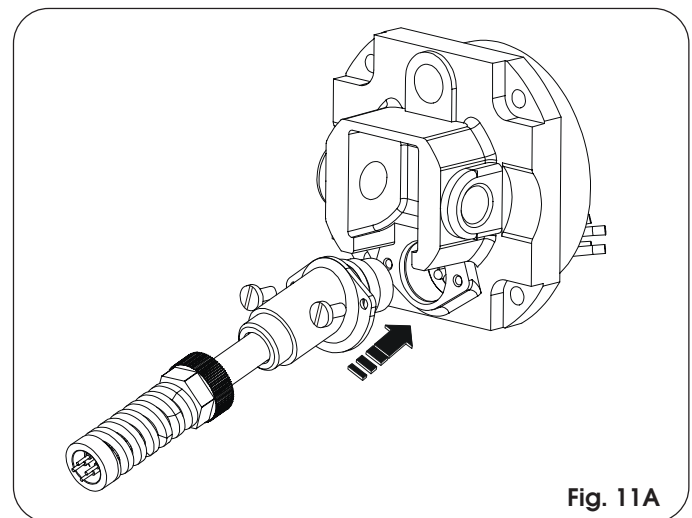

Fig. 11A

4. START-UP

- Connect the power cable of the operator (Fig.11A).
- Fasten the screws (Fig. 11A).

4.1. ADJUSTING THE ANTI-CRUSHING SYSTEM

The 422 automated system has an anti-crushing safety device which limits the operator's force if an obstacle is encountered while the gate is moving. To adjust the intervention threshold of the anti-crushing system, temporarily open the release unit.

- Lift the protective plug (Fig. 12, ref. ①) and fit the supplied key (Fig. 12, ref. ②).

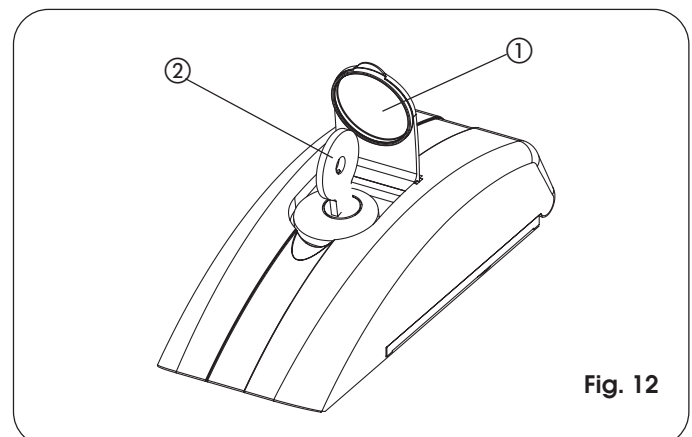

Fig. 12

- Turn the key 90° clockwise to open the cover.
- Lift up the cover (Fig. 13).
- Back off the screw (Fig. 13, ref. ③) which secures the knob, and withdraw the knob (Fig. 13, ref. ④).
- Turn the force adjustment screws (By-Pass) (Fig. 13, ref. ⑤ and ⑥) on the operator.
- OPEN screw (green wording) : gate opening direction.
- CLOSE screw (red wording) : gate closing direction.
- To reduce torque, turn the screws anti-clockwise.
- To increase torque, turn the screws clockwise.
- When you have finished adjusting, re-position the knob (Fig. 13, ref. ④) and fasten the screw (Fig. 13, ref. ③).
- Close the cover and lock it by turning the key anti-clockwise.

To adjust the torque limiters, consult Standards EN 12453 and EN 12445 for EU member countries and current legal regulations in the other countries.

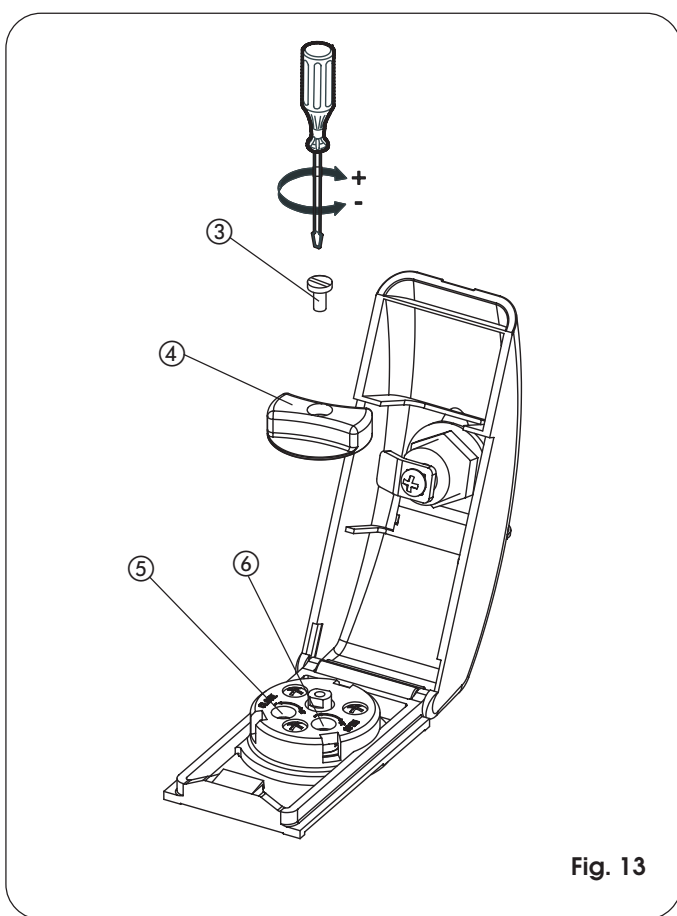

Fig. 13

5. FINAL OPERATIONS

Finish the installation operations as follows:

- Close the cover of the release device with the key.
- Remove the breather screw (Fig. 14, ref. ②)

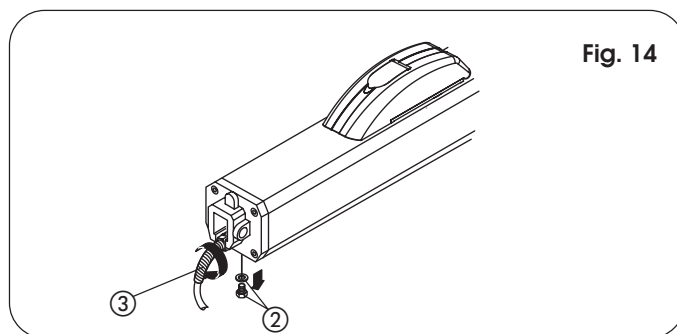

Fig. 14

6. AUTOMATED SYSTEM TEST

When you have finished installing, apply the danger signal sticker on the side of the operator so that it is clearly visible (Fig. 15). Run an accurate functional check of the automated system and of all the accessories connected to it, especially the safety devices. Hand the "User's Guide" to the Client, explain correct operation and use of the operator, and indicate the potentially dangerous areas of the automated system.

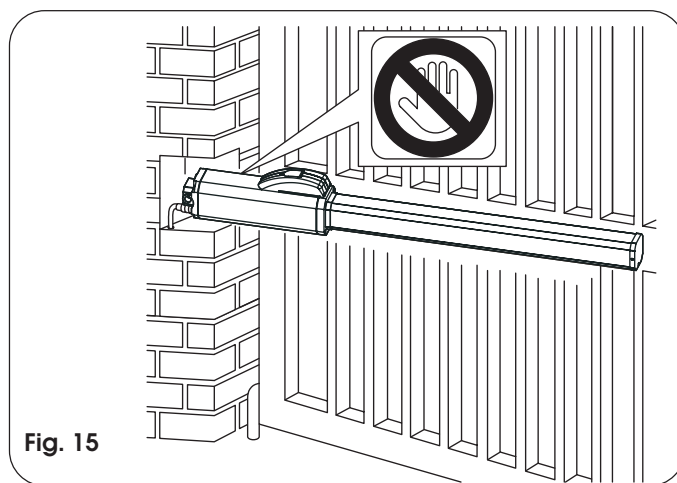

Fig. 15

7. MANUAL OPERATION

If the gate has to be moved manually due to a power cut or fault of the automated system, use the release device as follows:

- Lift the protective plug (Fig. 16, ref. ①) and fit the supplied key (Fig. 16, ref. ②).
- Turn the key 90° clockwise to open the cover.
- Lift up the cover (Fig. 16 ref. ③).
- Turn the release knob anti-clockwise for about two turns (Fig. 16, ref. ④).
- Open or close the leaf manually.

8. RESTORING NORMAL OPERATION MODE

To prevent an involuntary pulse from activating the operator during the manoeuvre, cut power to the system before re-locking the operator.

- To re-lock the operator, turn the release knob clockwise until it stops (Fig. 16, ref. ④).
- Close the cover and turn the key 90° anti-clockwise (Fig. 16, ref. ②).
- Finally, remove the key and close the protective plug (Fig. 16, ref. ①).

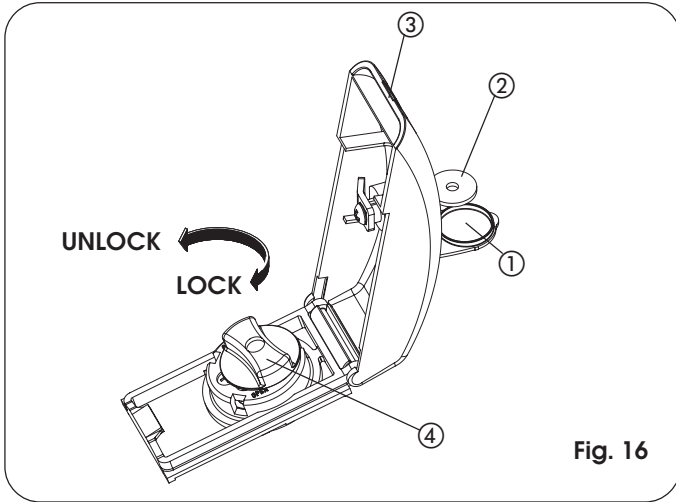

Fig. 16

9. SPECIAL APPLICATIONS FOR SWING LEAF GATES

9.1. OPENING TOWARD THE OUTSIDE, WITH OPERATOR INSTALLED INSIDE (Fig. 17)

For this special application, refer to Table 1, and select the STANDARD operator according to leaf length.

For leaves with a length of up to 1,8 m, we advise you to use the CBAC STANDARD operators.

For leaves longer than 1,8 m, we advise you to use only operators without the hydraulic locking, externally installing the ground level electric lock too. The installation dimensions are shown in table C. Instructions to adjust the anti-crushing system for outward opening gates only, contrary to what we indicated in paragraph 4.1:

- OPEN screw (green wording) : gate closing direction.
- CLOSE screw (red wording) : gate opening direction.
- To reduce torque, turn the screws anti-clockwise.
- To increase torque, turn the screws clockwise.

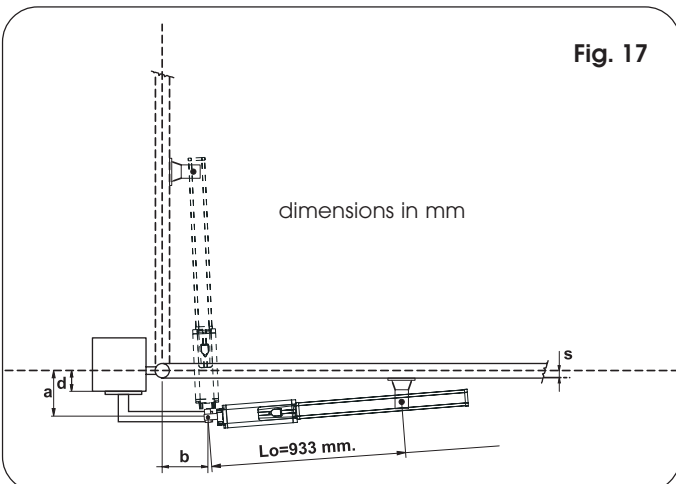

Fig. 17

Table C: Recommended dimensions for standard operators

Opening angle	a (mm)	b (mm)	s (mm)	d(**) (mm)	c(*) (mm)
90°	100	90	0	50	240
90°	110	100	0	60	240
90°	120	110	0	70	240

(*) Rod effective stroke (**) maximum dimension

10. MAINTENANCE

Run a functional check of the system at least every 6 months, with special attention to the efficiency of the safety and release devices (including the thrust force of the operator), and to perfect operation of the gate hinges.

Also, periodically check quantity of oil inside the tank.

Oil level check instructions:

- Cut power to the system.
- Position the operator vertically, with the rear flange high up.
- Remove the oil filling plug.
- Insert a screwdriver until it comes into contact with the electric motor as shown in Fig. 18.
- Remove the screwdriver and check oil level as shown in Fig. 18.

⚠ USE ONLY FAAC HP FLUID OIL

Periodically check correct adjustment of the anti-crushing safety device (BY-PASS) and the efficiency of the release system to allow manual operation (see relevant paragraph).

The safety devices installed on the system must be checked every 6 months.

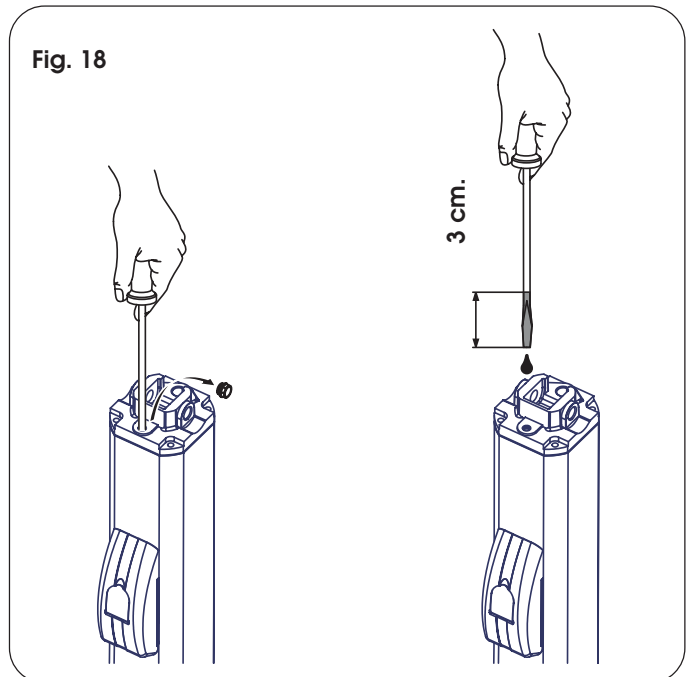

Fig. 18

11. REPAIRS

For any repairs, contact FAAC's authorised Repair Centres.

12. TROUBLESHOOTING

The following table will help you identify and solve some particular conditions.

	CONDITION	SUGGESTION
A	Gate not moving.	<ul style="list-style-type: none"> - Check if mains power is supplied. - Make sure that the operator is not unlocked. (chapter 8.). - Check the adjustment of the anti-crushing system (paragraph 4.1). - Check oil level inside the tank. (chapter 10 - Fig. 18). - Check the connection and operation of the thrust capacitor. - Check the efficiency of the electronic control unit.
B	Gate moving slowly.	<ul style="list-style-type: none"> - Check the adjustment of the anti-crushing system (paragraph 4.1).
C	Gate moving jogwise.	<ul style="list-style-type: none"> - Make sure that you have removed the breather screw (chapter 5). - Run some complete gate opening and closing cycles, in order to release any air inside the piston.
D	The operator is losing oil from the breather screw.	<ul style="list-style-type: none"> - An initial, minimum oil leak is normal. A larger leak may occur if the operator is not fitted in a perfectly horizontal plane. If the oil leak does not stop soon, we advise you to visit an authorised repair centre.
E	The leaves stop at slow-down.	<ul style="list-style-type: none"> - Check the adjustment of the anti-crushing system (paragraph 4.1).
F	Gate speed not constant.	<ul style="list-style-type: none"> - Incorrect installation dimensions (paragraph 3.2).

Notes

USER'S GUIDE

AUTOMATED SYSTEM 422

Read the instructions carefully before using the product and store them for future use

GENERAL SAFETY REGULATIONS

If correctly installed and used, the 422 automated system ensures a high degree of safety.

Some simple rules on behaviour can prevent accidental trouble:

- Do not pass between the leaves when they are moving. Wait for the leaves to open fully before passing through them.
- Do not, on any account stay in between the leaves.
- Do not stand near the automated system, and do not allow children, persons or things to do so, especially when it is operating.
- Keep remote controls or other pulse generators away from children, to prevent the automated system from being activated involuntarily.
- Do not allow children to play with the automated system.
- Do not willingly obstruct leaves movement.
- Prevent any branches or shrubs from interfering with leaves movement.
- Keep indicator-lights efficient and easy to see.
- Do not attempt to activate the leaves by hand unless you have released them.
- In the event of malfunctions, release the leaves to allow access and wait for qualified technical personnel to do the necessary work.
- When you have set manual operation mode, cut power to the system before restoring normal operation.
- Do not in any way modify the components of the automated system.
- Do not attempt any kind of repair of direct action whatever and contact qualified personnel only.
- At least every six months: arrange a check by qualified personnel of the automated system, safety devices and earth connection.

DESCRIPTION

These instructions apply to the following models:
422 CBCS - 422 CBACS - 422 SBS - 422 CBC - 422 CBAC - 422 SB - 422 CBC PED. - 422 SB PED.

The FAAC 422 automated system for swing leaf gates consists of a hydraulic enbloc composed of an electric pump and a hydraulic piston which transmits drive to the leaf.

The models with a hydraulic locking do not require installation of an electric lock, as they guarantee mechanical locking of the leaf when the motor is not operating.

The other models, without a hydraulic locking always require one or more electric locks to ensure the leaf is mechanically locked. Leaves of up to 3 mt can be automated depending on the selected model.

The functioning of the operators is controlled by an electronic control unit, housed in an enclosure with adequate degree of protection against atmosphere agents.

The leaves are normally closed.

When the electronic control unit receives an opening command from the radio control or any other pulse generator, it activates the hydraulic appliance which rotates the leaves until they reach the opening position to allow access.

If automatic mode was set, the leaves close automatically after selected pause time has elapsed.

If the semi-automatic mode was set, a second pulse must be sent to close the leaf again.

A stop pulse (if supplied) always stops movement.

For details on the behaviour of the automated system in different function logics, consult the installer.

Automated systems include safety devices (photocells) that prevent the leaves from moving when there is an obstacle in the area they protect.

The 422 automated system is supplied standard with a hydraulic anti-crush protection safety device (BY-PASS) which limits the torque transmitted to the leaves.

The warning-light indicates the current leaf movement.

MANUAL OPERATION

If the gate has to be moved manually due to a power cut or fault of the automated system, the release unit must be temporarily opened (fig.1).

- Remove the protective plug and insert the supplied key.
- Turn the key 90° clockwise to open the cover.
- Lift up the cover.
- Turn the release knob anti-clockwise for about two turns. Open or close the leaf manually.

N.B.: IN MODELS WITHOUT THE LOCKS, ALL YOU HAVE TO DO IS TO MANUALLY RELEASE THE ELECTRIC LOCK.

RESTORING NORMAL OPERATION MODE

Before re-locking the operator, cut power to the system. Turn the release knob clockwise until it stops.

Close the cover and turn the key 90° anti-clockwise. Finally, remove the key and close the protective plug.

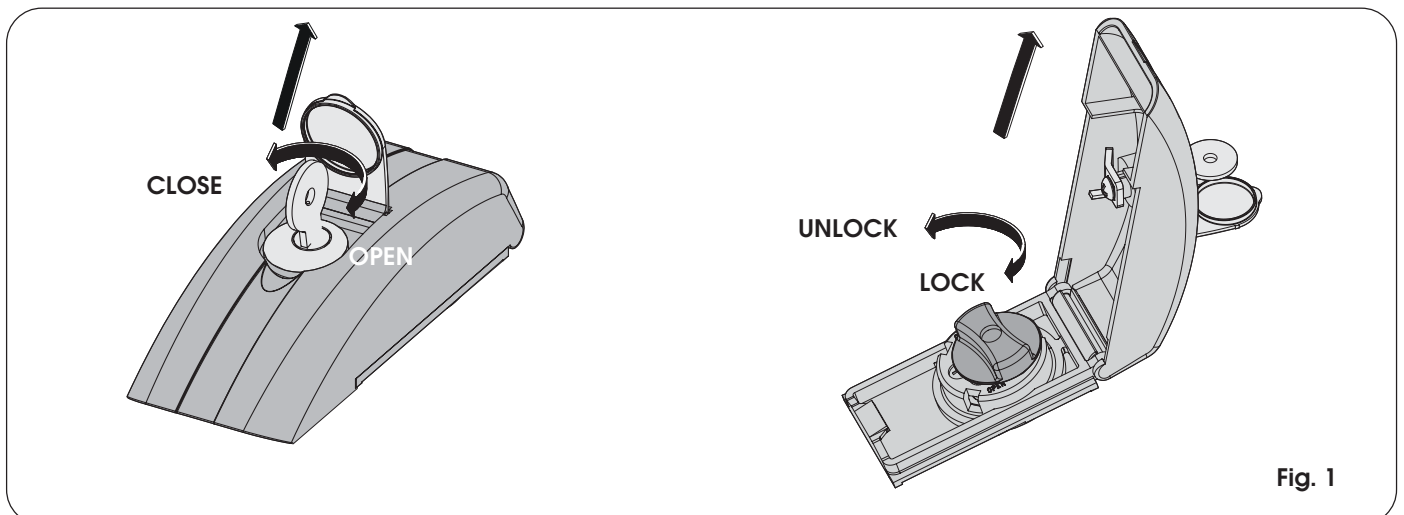

Fig. 1

MAINTENANCE REGISTER

Installation technician _____
 Customer _____
 Type of system _____
 Serial number _____
 Installation date _____ Activation _____

System configuration

PART	MODEL	SERIAL NUMBER
Actuatore	FAAC422	
Safety device 1		
Safety device 2		
Pair of photocells 1		
Pair of photocells 2		
Control device 1		
Control device 2		
Radio control		
Flashing lamp		
Other device		
Other device		

Indication of residual risks and of foreseeable improper use

No.	Date	Description of job	Signatures
1			Technician
			Customer
2			Technician
			Customer
3			Technician
			Customer
4			Technician
			Customer
5			Technician
			Customer
6			Technician
			Customer
7			Technician
			Customer
8			Technician
			Customer
9			Technician
			Customer
10			Technician
			Customer